



Sierra
Gear & Axle



**DIFFERENTIAL
REPAIR
AND
INSTALLATION
INSTRUCTIONS**

158004
1-1-87
28/07
50 000-50



Differential Repair and Installation Instructions

Please read completely before beginning!

You can expect many years and many miles of dependable use from your differential if it is set up properly and if you use only top quality parts.

You already have quality parts if you bought a Sierra kit. By following these instructions carefully, you will achieve proper set up.

We sincerely hope that these instructions are helpful.

**Sierra Gear & Axle
Technical Support**

(800) 792-2714

© Copyright Sierra Gear & Axle 2015

TABLE OF CONTENTS

Parts Identification.....	4
Tool List.....	5
Disassembly / Inspection.....	6
Adjustments.....	7
Parts Preparation.....	7
Initial Assembly.....	7
Component Clearancing.....	8
Assembly - Pinion.....	9
Assembly - Carrier.....	10
Checking the Pattern.....	11
Gear Tooth Nomenclature.....	12
Patterns - Acceptable.....	13
Patterns - Pinion Too Shallow.....	14
Patterns - Pinion Too Deep.....	15
Setup Specifications.....	16-17
Gear Oil.....	17
Additives.....	17
Break-In Procedure.....	17
Shim Combination Worksheet.....	18
Warranty Information.....	Back Cover

PARTS IDENTIFICATION

Typical Semi-Float Rear Axle

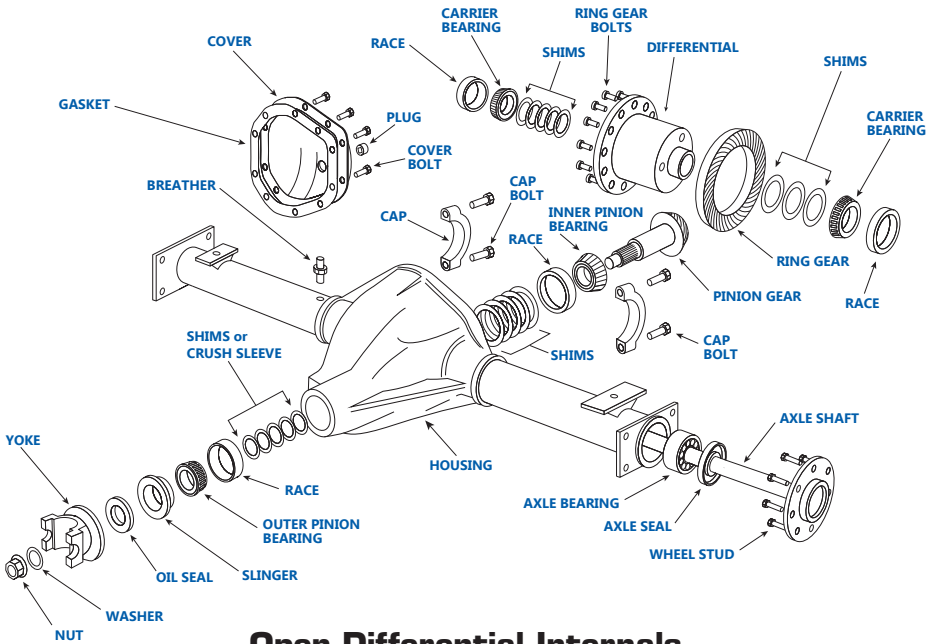

Open Differential Internals

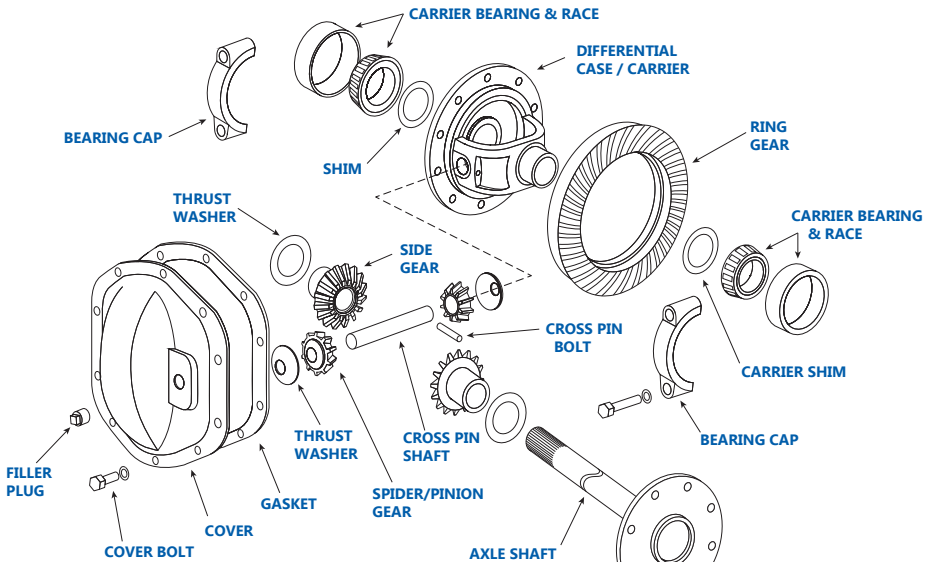

© Copyright Sierra Gear & Axle 2015

When working on your differential you will need a wide variety of tools. Using the correct tools saves time and helps prevent parts from being damaged.

Recommended Tools:

- Dial indicator
- Gear marking compound and a clean brush
- Calipers or a micrometer
- Bearing pullers
- Bearing press
- Three foot long breaker bar or strong impact gun
- Pinion nut socket
- Ring gear bolt socket
- Main cap bolt socket
- Six point cross pin bolt wrench
- Brake line wrench
- Pry bars for removing the carrier case
- 24 oz Ball peen hammer
- 48 oz sledge hammer
- 48 oz plastic dead blow hammer
- Assorted brass punches
- Punch for marking carrier caps
- Oil drain pan
- Foot pounds torque wrench
- Inch pounds torque wrench



© Copyright Sierra Gear & Axle 2015

DISASSEMBLY

Preparation

Make sure that you have all the parts and tools you will need. The extent of disassembly depends on the job being done and the inspection findings. Lift the vehicle using an appropriate lift or a jack and safe jack stands. Always make certain that the vehicle is safely supported before working underneath. Unbolt the driveshaft from the yoke. Remove the differential cover or unbolt the third member. Let the oil drain into a suitable container. Please recycle your waste oil. Remove c-clip axles by removing the differential cross pin bolt and cross pin shaft, pushing the axles in and pulling the c-clips. Full float axles are unbolted at the hubs. Punch both carrier caps with identification marks so that you will be able to re-install them on the same side and in the same direction. Most carriers can be pulled out of the housing with a pry bar. Further disassembly depends on the job being done. If you're changing the ring and pinion or the pinion bearings, remove the pinion nut with an air gun while holding the yoke, or use a long breaker bar and brace the yoke (bolt it to a long board) so that it can't move. Knock the pinion gear out to the rear with a brass punch taking care not to damage the threads. Keep track of the positions of all of the original shims. Pinion bearings must be pressed off. Carrier bearings can be pulled using a bearing puller. Internal parts (inside the carrier) can be moved as necessary.

Inspection

Inspect all bearings and races for pitting or uneven wear. The inner carrier bearing races should not spin on the carrier journals. The carrier races should have a snug fit in the housing. Inspect the carrier race bores for grooves from spinning races. "Spun" carriers and housings can be machined to accept slightly larger races and bearings. The side gear bores inside the carrier should not have any abnormal wear. All gear teeth should be smooth but not excessively shiny. Inspect gear teeth for pitting, chips, breaks, and for signs of uneven wear and overheating. Inspect positraction clutches for scoring and wear. Inspect the axles for pitted, grooved, or dull and rough bearing surfaces. Check for worn axle splines. All questionable parts should be replaced.

© Copyright Sierra Gear & Axle 2015

Differential Adjustments

The four essential differential adjustments are [pinion depth](#), [pinion bearing preload](#), [backlash](#) and [carrier bearing preload](#). The tables on page 18 can be used to write down shim combinations and results.

Preparing Parts

Clean all new and used parts with clean solvent. Dry the parts. De-burr the back of the ring gear and carrier mounting surface with a file or wet stone. Wash out the housing with solvent and check all of the oil passages to make certain that there are NO metal particles or dirt that can lead to early wear. Many housings have oil passages to the pinion and grooves just outside of the carrier bearings. Push rags through the axle tubes using solvent or brake cleaner until they are clean. Polish all seal surfaces with light emery cloth or fine sandpaper and then wipe them with a clean rag and clean oil or solvent to remove metal particles. Use a moderate coat of gear oil (not grease!) on all bearings and grease on all seals and seal surfaces just prior to installation.

Initial Assembly

We have successfully set up thousands of differentials without using a pinion depth setting tool. Pinion depth shims either go under the rear pinion race or on the pinion shaft under the rear pinion bearing. The diameter of your shims will determine where they go. Try using the original shim depth for your first attempt. The rear pinion bearing must be pressed on the pinion shaft and the pinion races must be tapped into the housing with a large punch so that they seat evenly. Install the front bearing and carefully tap the pinion seal in place with an old race. Ford 8" and 9", and GM 10.5" and H072 use a pilot bearing which must be tapped in, with a retainer for the Fords. Mount the ring gear to the carrier with a drop of red Loctite on each bolt. Carrier bearings are pressed on the carrier and secured with green Loctite. Note that in Dana Spicer differentials the carrier shims go between the carrier and carrier bearings.

Again, try using the original shim configuration.

COMMON ISSUES

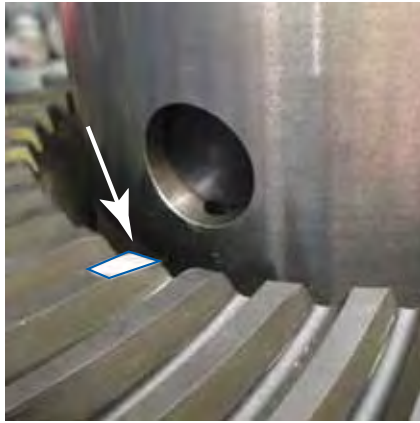

Cross-Pin Clearancing

Some numerically higher ratio gearsets are thick enough to require a small amount of grinding to allow for cross-pin installation. Determine which tooth or teeth are interfering with the cross pin and remove a small amount of material from tooth or teeth as shown. De-burr and clean the area thoroughly. This will not affect gear performance as this area is not within the contact area of the gears.

Jeep® JK Locker Sensor

Wranglers with electric lockers have a sensor that indicates when the differential is locked. The head of the plunger on the sensor must be past the ring as shown to function correctly. To make sure the plunger is in the correct position, be sure to slide the differential in straight.

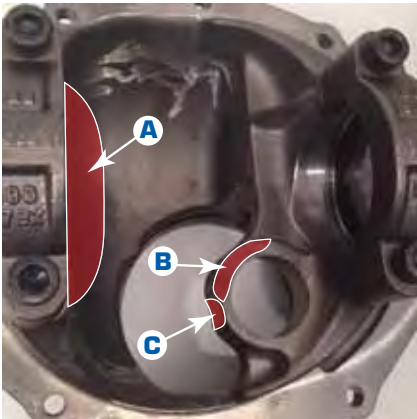

Ford 9" Dropouts

When installing an ARB Air Locker, some material may need to be removed from area (A) for carrier clearance. When installing a numerically higher ratio gear, the increased ring gear thickness may result in contact at the inner pinion bearing support (B). Some differential carriers may also contact the bearing support as indicated at point (C). Always remove the least amount of material possible to correct any clearance issues.

© Copyright Sierra Gear & Axle 2015

Install Pinion Gear and Set Pinion Bearing Preload

Pinion bearing preload is measured in **inch-pounds** and is a measure of the rolling resistance of the pinion bearings after proper torque has been applied to the pinion nut. Set the preload carefully (see “Specifications”) so that the bearings will have a long life. Use oil on the pinion nut washer surface during all assemblies and red loctite on the pinion nut threads during the final assembly.

Crush Sleeve Design: If you are unsure about getting the correct pinion depth, it may be easier to install the pinion without a crush sleeve until the correct pinion depth has been established. Always use a new crush sleeve for final assembly. Slide the crush sleeve on the pinion shaft (unless you are using the trial and error method) and install the pinion through the rear of the housing. The yoke usually must be placed on while applying pressure on the pinion gear head to hold it in place. Use an impact wrench or huge breaker bar to apply the torque necessary to crush the sleeve. Proceed very slowly so that you don't overload the bearings. The pinion preload will be zero until the bearings contact the races but will then increase very quickly. Use an **inch-pound** torque wrench to check the preload. If the pinion bearing preload exceeds the specified allowable range, install another new crush sleeve and start over!

Preload Shim Design: Clean the shims completely so that there are no particles that may cause a false preload reading or cause the shim stack to change thickness over time as the vehicle is driven. Slide the shim pack over the pinion shaft to the shelf. Use the original shims on the first assembly or add 0.003” to the original preload shims to make up for the bearings settling into the housing. Tighten the pinion nut to approximately 250 foot pounds. Go slowly so as to not damage the bearing if the preload shim stack is not thick enough. Use an **inch-pound** torque wrench to check the preload. If the preload is too loose then remove the shims so that the bearings will be tighter against the races and increase the preload. If the preload is too tight, then remove the pinion gear and add shims so that the bearings will not be as tight against the races.

All Designs: After reaching the correct preload, moderately tap both ends of the pinion to seat the bearings, races and yoke. Be careful not to hit the pinion so hard that it damages the bearings. After “seating” the pinion, check the pinion bearing preload again.

© Copyright Sierra Gear & Axle 2015

ASSEMBLY

Install Carrier and Adjust Carrier Preload and Backlash

Carrier bearing preload is not specifically measured, but a good tight fit is important in all differential designs. Inadequate carrier bearing preload allows the carrier to move when under load and this can cause the backlash to open up. Check the backlash by mounting a dial indicator to the housing with the plunger set perpendicular to the ring gear teeth. Hold the pinion yoke and rotate the ring gear back and forth. See the specifications section. The backlash will generally change about 0.007" for each 0.010" that the carrier is moved. To decrease the backlash, move the carrier closer to the pinion centerline. To increase the backlash, move the carrier away from the pinion centerline.

Screw Adjuster Design: Oil the adjuster threads on both the housing and on the adjusters themselves. While holding the races on the bearings, place the carrier in the housing. Install the carrier caps according to the marks made during assembly so that the threads are seated evenly on the adjusters. Third member differential designs require a 10 to 12 inch spanner wrench to tighten the adjusters. Chrysler differential designs require an extension bar and special spanner to access the adjusters through the axle tubes. Tighten both the left and right adjusters evenly by hand until they are fairly tight. If the backlash is too wide, tighten the left adjuster until the backlash is correct. If the backlash is too tight, tighten the right adjuster until the backlash is correct. If necessary, open one adjuster and tighten the other. Both adjusters must be fully hand tightened when acceptable backlash is obtained. The final adjustment should tighten the left adjuster since the ring gear is forced away from the pinion gear while under load.

Shim Design: Some differentials use shims between the carrier bearing races and the housing and some use shims between the carrier bearing and the carrier case. Carrier bearing preload is established by the tightness of the shims. The carrier should be shimmed tight enough that it must be tapped in with a plastic dead blow hammer. While holding the races on the bearings (and outside shims on the races) start the carrier into the housing and tap it in with the hammer. Install the carrier caps according to the marks made during disassembly. Check the backlash. If the backlash is too wide, move or add shims to the left side. If the backlash is too tight, move or add shims to the right side.

© Copyright Sierra Gear & Axle 2015

Checking the Pattern

Check the pattern for proper pinion depth only after setting the backlash. Brush three or four of the ring gear teeth with a moderate coat of gear marking compound in two different places on the ring gear. Rotate the ring gear past the pinion gear three or four times and then back so the pattern can be seen.



Pinion depth is indicated by the position of the pattern between the face and flank of the ring gear teeth. Backlash affects the pattern position between the heel and toe of the ring gear teeth. Housing alignment and pinion bearing bore alignment can also affect the pattern from heel to toe and can not be corrected without machine work. In some cases an ideal heel to toe pattern can not be achieved. If the backlash is within specifications, you may not be able to improve the heel to toe pattern. A contact pattern that is centered from face to flank always indicates correct pinion depth, even if a pattern that is centered from heel to toe can not be obtained.

If the contact pattern is towards the face of the ring gear teeth then the pinion is too far away from the ring gear. Adjust the pinion shims to move the pinion gear towards the ring gear centerline (add shims, subtract shims for pinion support designs). If the contact pattern is towards the flank of the ring gear teeth then the pinion is too close to the ring gear. Adjust the pinion shims to move the pinion gear away from the ring gear centerline (subtract shims; add shims for pinion support designs).

When changing the pinion depth, make large changes; (0.005" to 0.015") until the pattern is close. By making adjustments that move the pinion too far, you can determine that the correct pattern is somewhere between the two extremes. Then make smaller changes; (0.002" to 0.004") until the pattern is centered between the face and the flank of the ring gear teeth.

When setting up a used ring & pinion, pay more attention to the pattern on the coast side of the ring gear teeth and pay less attention to the drive side. Low mileage gears should be patterned as if new.

© Copyright Sierra Gear & Axle 2015

CONTACT PATTERN

Tooth Nomenclature

(Terms for describing specific areas of the gear teeth)

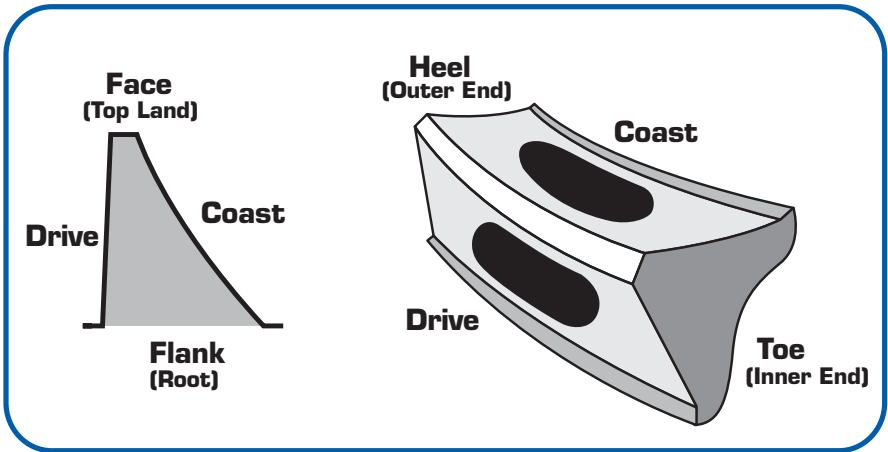

© Copyright Sigma Gear & Axle 2015

ACCEPTABLE PATTERNS

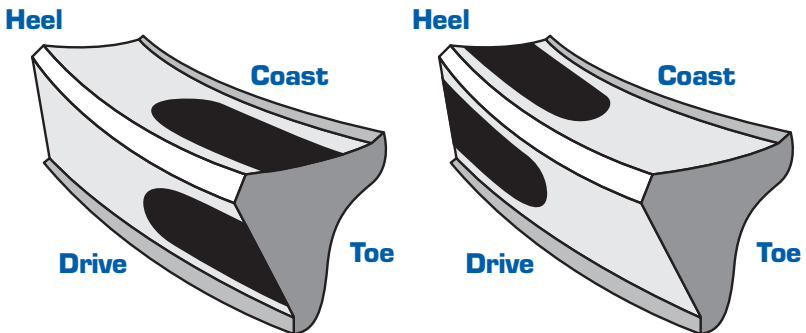
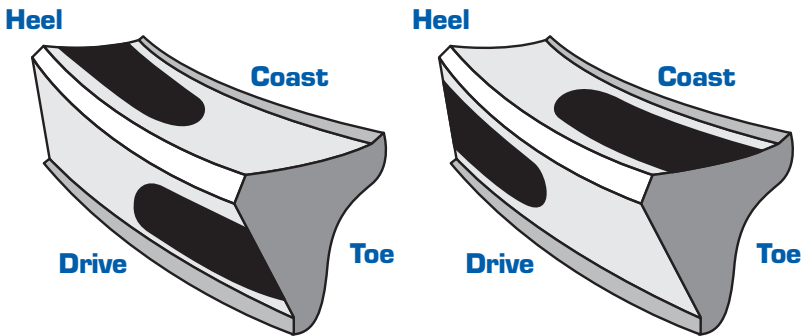
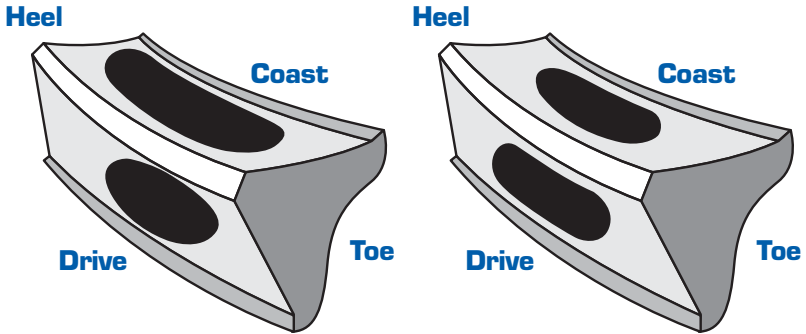

CONTACT PATTERN

PINION IS TOO SHALLOW

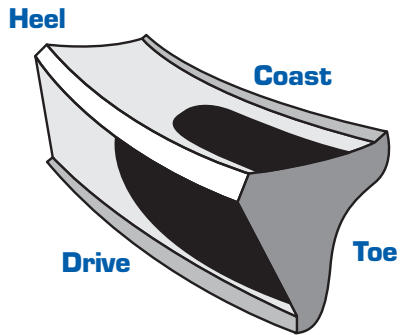
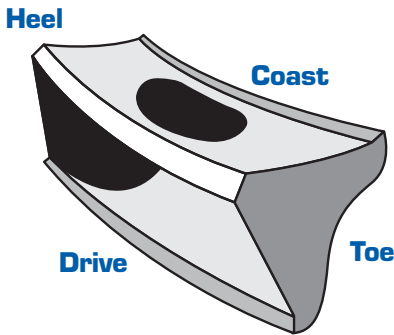
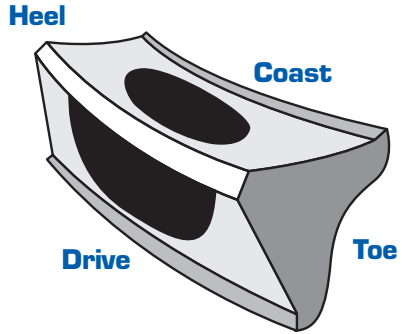
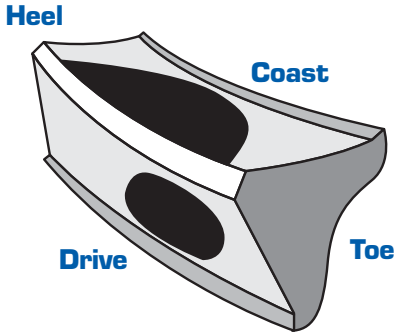
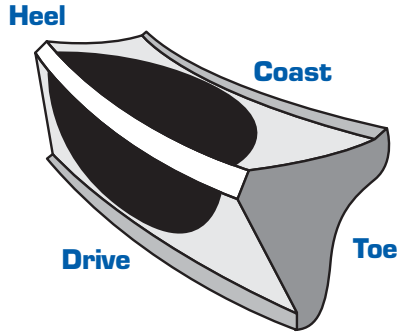
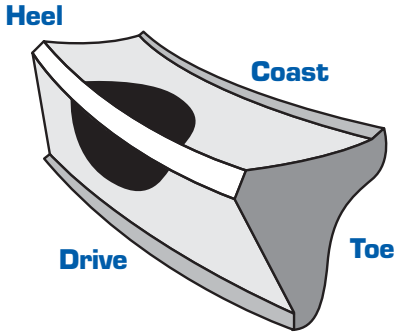

© Copyright Sierra Gear & Axle 2015

PINION IS TOO DEEP

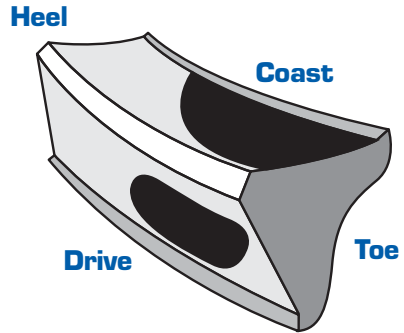
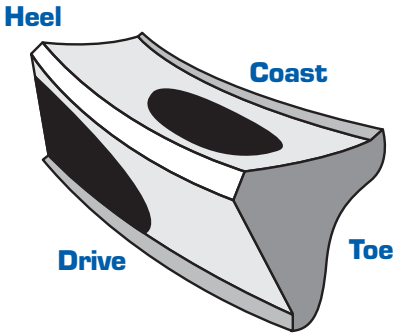
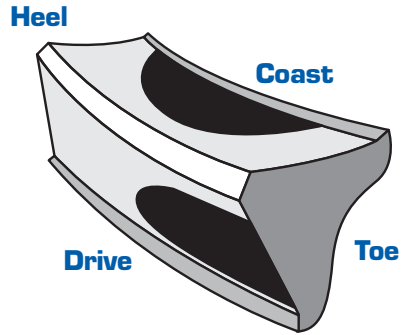
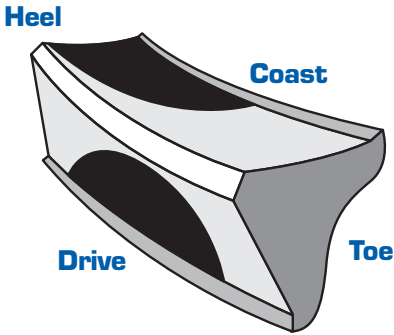
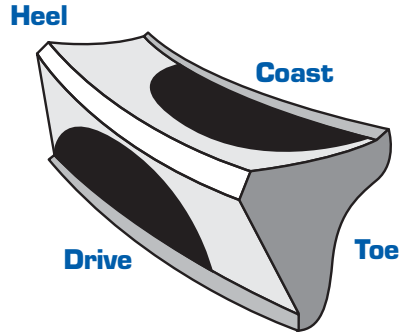
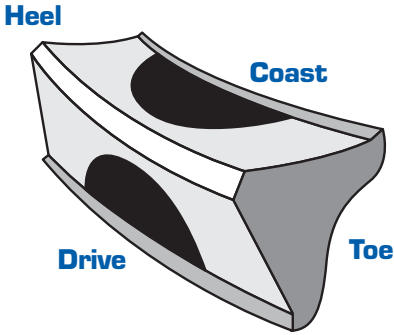

SETUP SPECIFICATIONS

DIFFERENTIAL MODEL	PINION BEARING PRELOAD - NEW (Inch Pounds)	PINION BEARING PRELOAD - USED (Inch Pounds)	BACKLASH (.001 inch)	RING GEAR BOLT TORQUE (Foot Pounds)	BEARING CAP TORQUE (Foot Pounds)
--------------------	--	---	----------------------	-------------------------------------	----------------------------------

AMC

MODEL 20	14-19	6-8	6-10	65	65
MODEL 35	12-15	6-7	6-10	55	55

CHRYSLER

7.25"	12-14	6-7	6-10	55	50
8" IFS	12-15	6-8	6-10	55	60
8.25"	12-15	6-8	6-10	55	60
8.75" - 41 Case	13-15	6-8	6-10	55	90
8.75" - 42 Case	15-25	7-10	6-10	55	90
8.75" - 89 Case	14-19	6-9	6-10	55	90
9.25"	14-19	6-9	6-10	65	75
9.25" Front	15-35	10-20	5-7	103	63
Chrysler/AAM 10.5"	15-25	10-20	5-7	175	120
Chrysler/AAM 11.5"	25-45	10-20	5-7	175	175

DANA SPICER

DANA 25	12-15	6-7	6-10	55	50
DANA 27	12-15	6-7	6-10	55	50
DANA 28	10-13	5-6	6-10	55	50
DANA 30	12-15	6-8	6-10	55	60
DANA 44	14-19	6-9	6-10	55	60
DANA 50	14-19	6-9	6-10	65	60
DANA 60, 61, 70U	17-30	8-10	6-10	110	80
DANA 70 & 70HD	20-35	8-10	6-10	110	80
DANA 80	25-40	9-11	4-10	175	80

FORD

7.5"	14-19	6-8	11-16*	60	60
8.0"	12-14	6-7	10-15*	60	60
8.7"	14-19	6-8	10-15	60	60
8.8"	14-19	6-8	11-16*	60	60
9" OEM R&P	13-15	6-7	10-16	70	60
9" NON-OEM	13-15	6-7	6-12	70	60
9" DAYTONA	14-16	6-8	6-12	70	60
9-3/8"	14-16	6-8	10-15	70	60
9.75"	15-19	6-8	10-15	75	70
10.25" & 10.5"	20-35	6-8	11-16	95	80

GMC

Olds/Pontiac Dropout	14-19	6-7	6-10	55	60
'63 - '79 Corvette	14-19	6-8	6-10	55	60
'55 Chevy Dropout	14-18	6-8	6-10	55	60
7.25"	11-14	6-7	6-10	55	60
7.5"	12-15	6-7	6-10	65	60
7.625" 2-Cut OEM	12-15	6-7	3-6	65	60
7.75"	12-15	6-7	6-10	65	60
8" 2-Cut OEM	12-15	6-7	3-6	65	60
8.2" Olds/Pontiac	12-15	6-7	6-10	55	60
8.25" IFS	14-19	6-8	6-10	65	55
8.5"	14-19	6-8	6-10	65	60
8.625" 2-Cut OEM	14-19	6-8	3-6	65	60
8.875" 12 Bolt Cap	14-19	6-8	6-10	55	60
8.875" 12 Bolt Truck	13-15	6-7	6-10	55	60
9.25" IFS	15-22	7-9	6-10	75	80

* Backlash Specs for Aftermarket Sets are .006-.012

SETUP SPECIFICATIONS

DIFFERENTIAL MODEL	PINION BEARING PRELOAD - NEW (Inch Pounds)	PINION BEARING PRELOAD - USED (Inch Pounds)	BACKLASH (.001 inch)	RING GEAR BOLT TORQUE (Foot Pounds)	BEARING CAP TORQUE (Foot Pounds)
GMC					
9.5"	15-22	7-9	6-10	103	63
10.5"	20-35	8-11	6-10	120	136
11.5"	25-45	10-20	3-10	175	153
H072	PRESET	PRESET	6-10	120	175
TOYOTA					
7.5"	12-15	5-6	6-10	70	70
8" Truck 4-Cyl.	12-15	5-6	6-10	70	70
Truck V6 & Turbo	14-17	5-6	6-10	70	70
Tacoma	14-17	5-6	6-10	70	70
Landcruiser	14-17	5-6	6-10	70	70
Landcruiser Front	14-17	5-6	6-10	70	70
SUZUKI					
Samurai	12-15	5-6	6-10	70	70

FINAL STEPS

Gaskets / Sealant - Use a gasket or 100% silicone to seal the cover or third member to the housing.

Gear Oil - Use only high quality brand name gear oil and fill the differential until the oil spills out the plug hole. We do not recommend using synthetic gear oil of any kind, especially for use with limited-slip/posi differentials.

Posi Additive - Positraction carriers require friction modifier / additive.

* New Gear Break-In Procedure *

All new gear sets require a break-in period to prevent damage from overheating. After driving the first 15 or 20 miles you MUST let the differential cool for at least 30-40 minutes before proceeding.

Drive 500 easy miles before towing.

Tow for very short distances (less than 15 miles) and let the differential cool before continuing during the first 45 towing miles. Change the gear oil after the first 500 miles. This will remove any metal particles or phosphorus coating that has come from the new gear set.

ANY OVERLOADING OR OVERHEATING CAN CAUSE THE GEAR OIL TO BREAK DOWN AND THE RING & PINION CAN FAIL.

© Copyright Sierra Gear & Axle 2015

SHIM COMBINATIONS & RESULTS

ATTENTION! Changing the depth shim may require the same change to the preload shim pack to keep the preload constant.

Trial Number	Preload Shim	Resulting Preload
1	0._____”	In lbs.
2	0._____”	In lbs.
3	0._____”	In lbs.
4	0._____”	In lbs.
5	0._____”	In lbs.
6	0._____”	In lbs.
7	0._____”	In lbs.
8	0._____”	In lbs.
9	0._____”	In lbs.

Trial Number	L. Carrier Shim	R. Carrier Shim	Resulting Backlash	Depth Shim	Drive Pattern	Coast Pattern
1	0.____”	0.____”	0.0____”	0._____”	Face/Flank	Face/Flank
2	0.____”	0.____”	0.0____”	0._____”	Face/Flank	Face/Flank
3	0.____”	0.____”	0.0____”	0._____”	Face/Flank	Face/Flank
4	0.____”	0.____”	0.0____”	0._____”	Face/Flank	Face/Flank
5	0.____”	0.____”	0.0____”	0._____”	Face/Flank	Face/Flank
6	0.____”	0.____”	0.0____”	0._____”	Face/Flank	Face/Flank
7	0.____”	0.____”	0.0____”	0._____”	Face/Flank	Face/Flank
8	0.____”	0.____”	0.0____”	0._____”	Face/Flank	Face/Flank
9	0.____”	0.____”	0.0____”	0._____”	Face/Flank	Face/Flank

© Copyright Sierra Gear & Axle 2015



Sierra
Gear & Axle

- **Ring & Pinion Gear Sets** •
- **Differential Repair & Installation Kits** •
- **Replacement & Performance Axle Shafts** •

WARRANTY INFORMATION

Sierra Gear & Axle products are covered by warranty policies that vary depending upon product type and category.

Ring & Pinion Gear Sets are guaranteed for one (1) year*

Installation Kits are guaranteed to contain components that are free from manufacturing defects.

Chromoly Axle Shafts are guaranteed against breakage for a period of 10 years.*

Replacement Axle Shafts are guaranteed for a period of two (2) years*

*Restrictions apply, call for details (800) 792-2714



Online at: www.sierragear.com